

TORRES IP44 WALL

Installation Guide

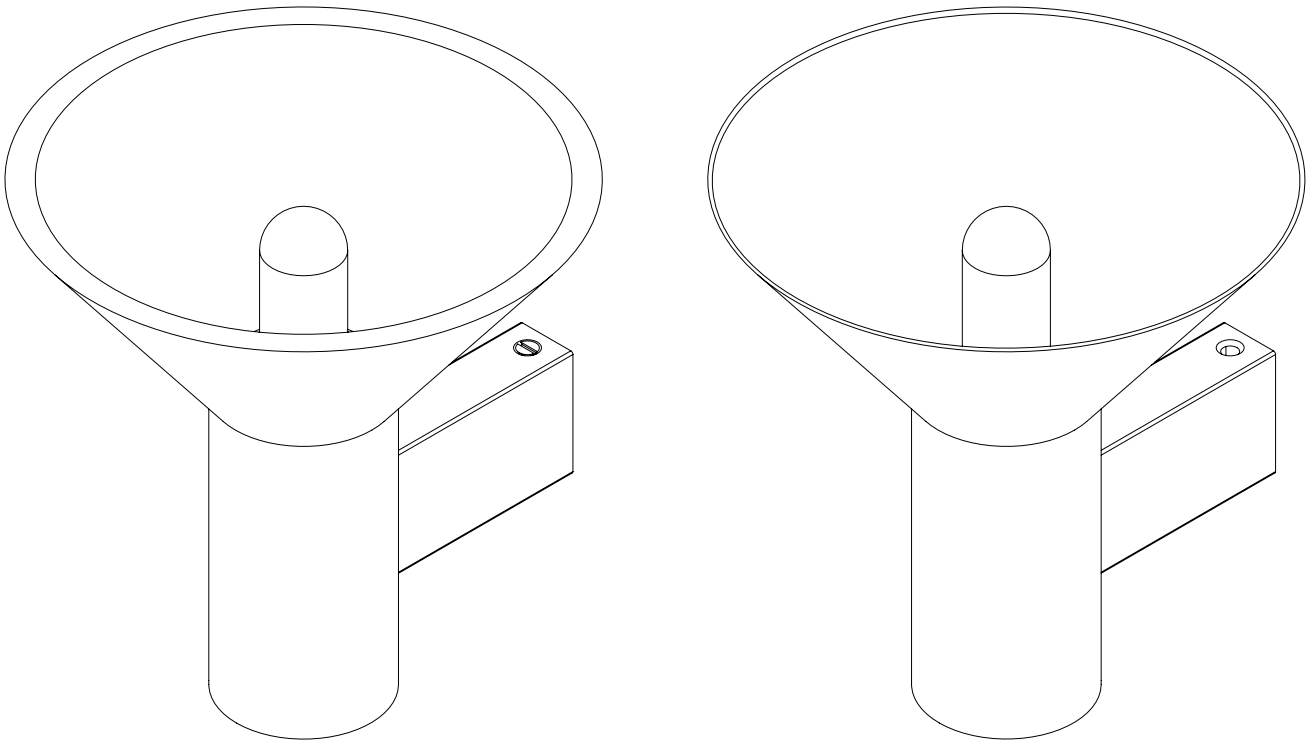

!

Please handle with care and wear gloves at all times during assembly and installation to avoid damaging components.

TECHNICAL

Bulb Holder
G9

Wattage
max 4W LED 2700k

Weight
2kg

PARTS & COMPONENTS

A. Body, wall mounting bracket, 2 x M4 Counter sunk machine screws

B. Body, wall mounting bracket, 2 x M4 Counter sunk machine screws, Cover Plate (110V ONLY)
C. 2 x M4 Bolts (110V ONLY)
D. US Adapter plate (110V ONLY)

240V

A.

Alabaster

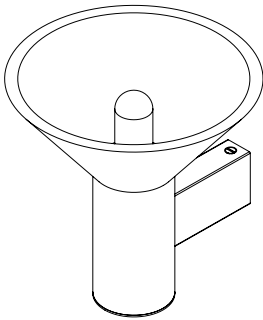

Brass

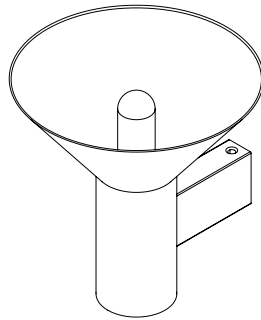

or

110V

B.

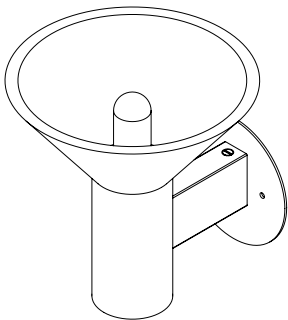

C.



D.

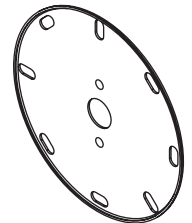

- All nuts and bolts required for the installation will be included in the delivery.



BEFORE INSTALLATION

- Check that you have all components before starting the installation.
 - Installation must be carried out by a qualified electrician.
 - A minimum of two people is required to install a pendant light.
- Check that the ceiling or wall fixings are suitable and strong enough to support the weight of the light fixture.
 - You will need the below specific tools for a successful installation.

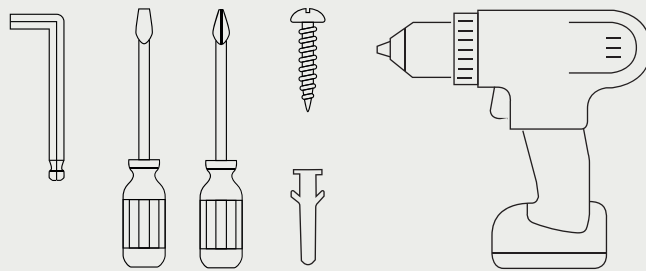

If the external flexible cable or cord of this luminaire is damaged, it shall be exclusively replaced by the manufacturer or his service agent or a similar qualified person in order to avoid a hazard.

1. Remove the wall bracket from the fitting by removing the two screws located on either side.

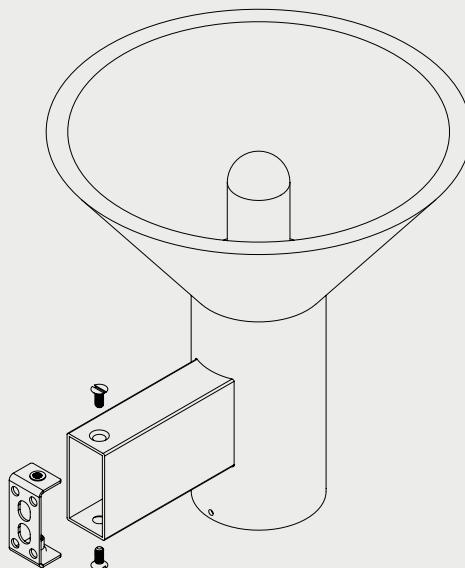

2. 240V

1. Securely fix the mounting plate to the wall using 4 x screws suitable for the surface you are mounting to (not supplied). Ensure that the mains cable is centred with the hole, either of hole can be used.

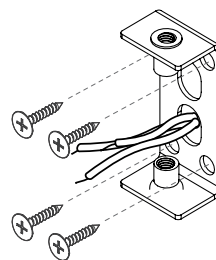

2. 110V

1. Securely fix the US adapter plate to junction box ensuring that the widest three holes are horizontally positioned.

2. Attach the mounting plate and covering plate to the Adapter plate using the 2 screws provided to securely attach the wall plate to the junction box.

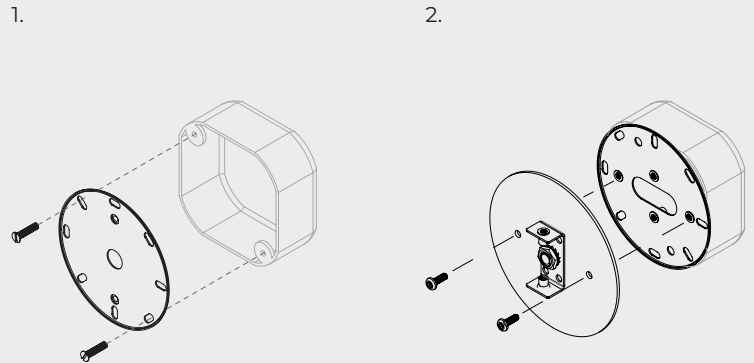

3.

Note:
Ensure that the weight of the fitting is fully supported during the electrical installation.

1. Connect fitting to mains input, insuring all wires are colour matched and the wall light is earthed correctly.

Ensure you are using suitable IP44 connectors (not included). Installation must be performed by a qualified person.

Any terminal blocks recommended must conform to IEC 60998-2-1 or IEC 60998-2-2

Terminal block - Specification
Type - Screw / screw less - IP44
No of terminals - 3
Rated voltage - 240v
Rated connecting capacity - AWG 24-12

2. Place the base over the mounted plate and secure with the two screws located on either side of the fitting.

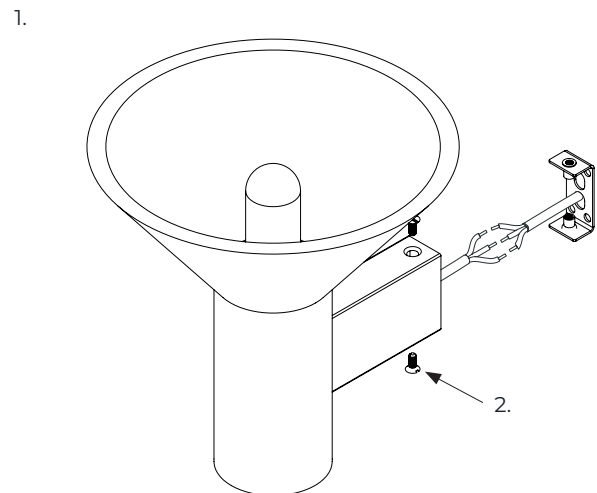

4.

Unscrew the glass dome and add 1 x G9 Bulb (max 4W LED 2700k).

Replace the glass dome.

Do not overtighten.
Ensure a good seal is made against the white gasket.

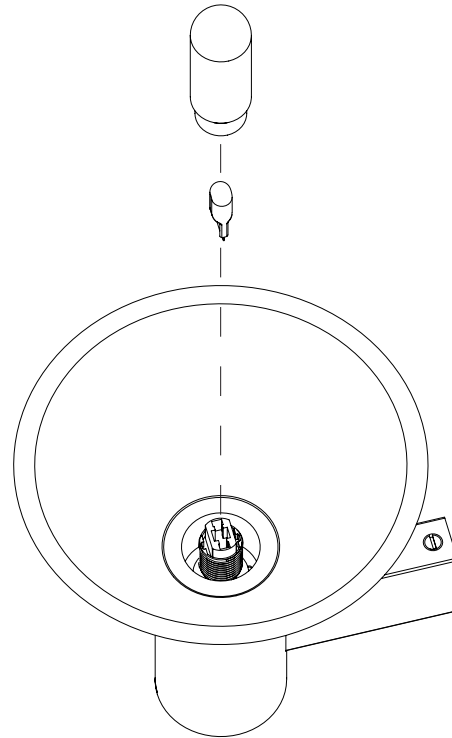

MAINTENANCE

Cleaning

Dust using a dry lint-free cloth weekly or as required

Repairs

Contact
CTO Lighting

Warranty

Please visit
www.ctolighting.co.uk/pages/f-a-q
for CTO warranty policy

Certification

